

UNITED STATES PATENT AND TRADEMARK OFFICE

BEFORE THE BOARD OF PATENT APPEALS
AND INTERFERENCES

GARY S. **ROUBIN**, GEOFFREY HAMILTON WHITE,
SRIRAM S. IYER, RUSSELL J. REDMOND, and CLAUDE A. VIDAL
Junior Party
(Patent Nos. 5,827,321, 6,475,236 and 6,106,548)¹

v.

PAUL H. **BURMEISTER**, CHARLES L. EUTENEUER,
BRIAN J. BROWN, PAUL J. FORDENBACHER, and
ANTHONY C. VRBA
Senior Party
(Application 09/427,291)²

Patent Interference No. 105,794
(Technology Center 3700)

Before: JAMESON LEE, SALLY GARDNER LANE and SALLY C. MEDLEY,
Administrative Patent Judges.

LEE, *Administrative Patent Judge.*

Judgment – Merits – Bd. R. 127

1

1 The real party in interest is Endosystems, LLC.

2 The real party in interest is Boston Scientific Scimed, Inc.

1 Junior party Roubin has not filed a preliminary statement. Junior party
2 Roubin has not attacked the accorded benefit dates of Senior Party Burmeister.
3 Junior party has indicated that it will not be filing a priority motion. Junior party
4 Roubin recognizes that it has in essence conceded priority. (Paper 26).

5 In a separate concurrent paper, we have denied junior party Roubin's Motion
6 1 to designate certain claims as not corresponding to the count. No other motion is
7 pending before the Board. Time is now appropriate to enter judgment against the
8 junior party. It is

9 **ORDERED** that judgment as to the subject matter of Count 1 is herein
10 entered against junior party GARY S. ROUBIN, GEOFFREY HAMILTON
11 WHITE, SRIRAM S. IYER, RUSSEL J. REDMOND, and CLAUDE A. VIDAL;

12 **FURTHER ORDERED** that junior party GARY S. ROUBIN, GEOFFREY
13 HAMILTON WHITE, SRIRAM S. IYER, RUSSEL J. REDMOND, and CLAUDE
14 A. VIDAL is not entitled to claims 1-54 of Patent 5,827,321, claims 1-25 of Patent
15 6,475,236, and claims 1-12 of Patent 6,106,548, which correspond to Count 1;

16 **FURTHER ORDERED** that claims 1-54 of Patent 5,827,321, claims 1-25
17 of Patent 6,475,236, and claims 1-12 of Patent 6,106,548 are herein cancelled;

18 **FURTHER ORDERED** that if there is a settlement agreement, the parties
19 should note the requirements of 35 U.S.C. § 135(c) and 37 CFR § 1.666; and

20 **FURTHER ORDERED** that a copy of this judgment be filed in the
21 respective involved application or patents of the parties.

22

23

Interference No. 105,794
Roubin v. Burmeister

By Electronic Transmission:

Counsel for junior party Roubin:

John T. Callahan
Keiko K. Takagi
SUGHRUE MION, PLLC
jcallahan@sughrue.com
ktakagi@sughrue.com

Counsel for senior party Burmeister:

William F. Lawrence
Stephen J. Lieb
Frommer Lawrence & Haug, LLP
wlawrence@flhlaw.com
slieb@flhlaw.com

UNITED STATES PATENT AND TRADEMARK OFFICE

BEFORE THE BOARD OF PATENT APPEALS
AND INTERFERENCES

GARY S. **ROUBIN**, GEOFFREY HAMILTON WHITE,
SRIRAM S. IYER, RUSSELL J. REDMOND, and CLAUDE A. VIDAL
Junior Party
(Patent Nos. 5,827,321, 6,475,236 and 6,106,548)

v.

PAUL H. **BURMEISTER**, CHARLES L. EUTENEUER,
BRIAN J. BROWN, PAUL J. FORDENBACHER, and
ANTHONY C. VRBA
Senior Party
(Application 09/427,291)

Patent Interference No. 105,794 (JL)
(Technology Center 3700)

Before LEE, LANE, and MEDLEY, *Administrative Patent Judges*.

LEE, *Administrative Patent Judge*.

Decision -- Motions -- Bd. R. 125(a)

1 This interference was declared on February 7, 2011. The sole authorized
2 motion is Roubin's Motion 1 which seeks to designate the following claims of
3 Roubin's involved patents as not corresponding to the count:

Interference No. 105,794
Roubin v. Burmeister

1 Patent 5,827,321: claims 8, 10-12, 16-19, and 21-54

2 Patent 6,475,236: claims 1-25

3 Patent 6,106,548: claims 1-12

4 Burmeister filed no opposition to Roubin's Motion 1. Nevertheless, for
5 failure to meet Roubin's applicable burden of proof, Roubin's Motion 1 is *denied*.

6 Findings of Fact

7 1. Junior party Roubin is involved in this interference on the basis of three
8 patents: Patent 5,827,321 (Roubin '321); Patent 6,475,236 (Roubin '236); and
9 Patent 6,106,548 (Roubin '548).

10 2. Senior party Burmeister is involved in this interference on the basis of
11 Application 09/427,291, filed October 26, 1999.

12 3. Roubin's real party in interest is Endosystems, LLC.

13 4. Burmeister's real party in interest is Boston Scientific Scimed, Inc.

14 5. The sole count in this interference is Count 1, which is defined as:

15 Claim 1 of Roubin's Patent 5,827,321

16 or

17 Claim 22 of Burmeister's Application 09/427,291

18 6. Claim 1 of Roubin's Patent 5,827,321 reads as follows:

19 1. A stent comprising:

20

21 a plurality of annular elements, each annular element having a
22 compressed state and an expanded state, wherein each annular
23 element has a longitudinal dimension which is smaller in the radially
24 expanded state than in the compressed state; and

25

26 connecting members connecting adjacent annular elements;

1 9. Roubin '321 discloses an expandable stent, and an expandable stent with a
2 tapered diameter, illustrated respectively in Figures 3 and 11A, reproduced
3 below:

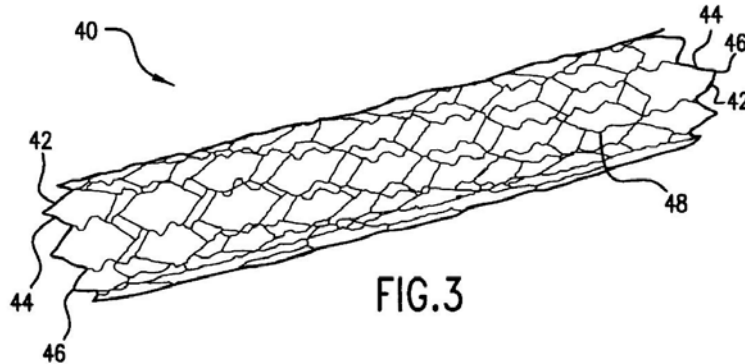

4

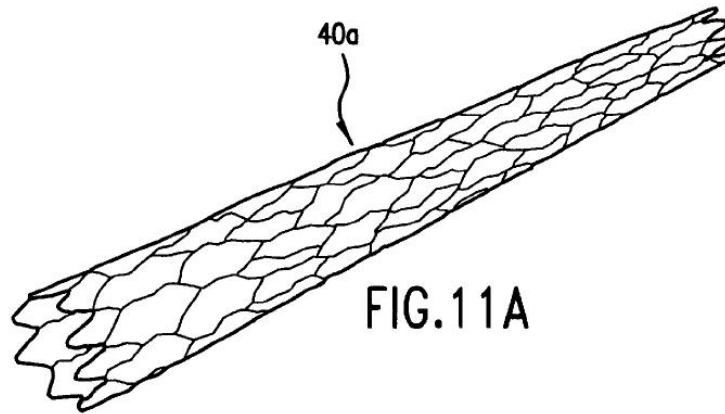

5

6 10. In Roubin '321 the preferred embodiment of a non-foreshortening
7 intraluminal stent is made up of a plurality of annular elements and connecting
8 members, wherein the connecting members vary in length to compensate for the
9 foreshortening of the annular elements. (Roubin '321 2:66-3:16).

10 11. Roubin's Motion 1 discusses the following references as applicable prior
11 art: Burmeister's WO 95/31945 publication (Burmeister WO); Jang's Patent

12

Interference No. 105,794
Roubin v. Burmeister

1 5,954,743 (Jang '743); Goicoechea's Patent 5,609,627 (Goicoechea
2 '627); and Fischell's Patent 5,749,825 (Fischell '825).

3 Burmeister WO

4 12. Burmeister WO discloses an expandable stent having annular elements
5 with connecting members that compensate for the foreshortening of expanded
6 annular elements (Burmeister WO 12:11-25), as illustrated in Figures 11a
7 (compressed state) & 11b (expanded state) reproduced below:

Fig. 11a

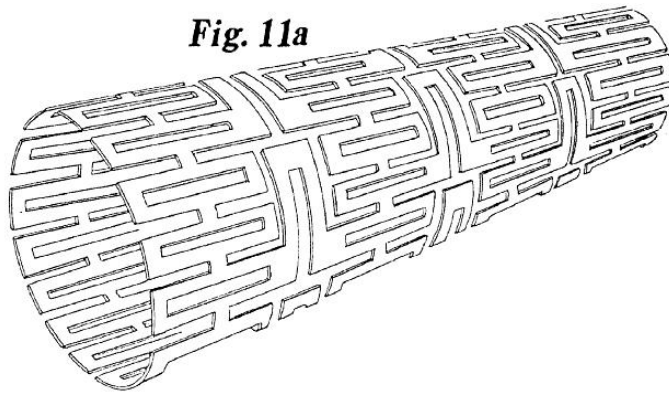

8

Fig. 11b

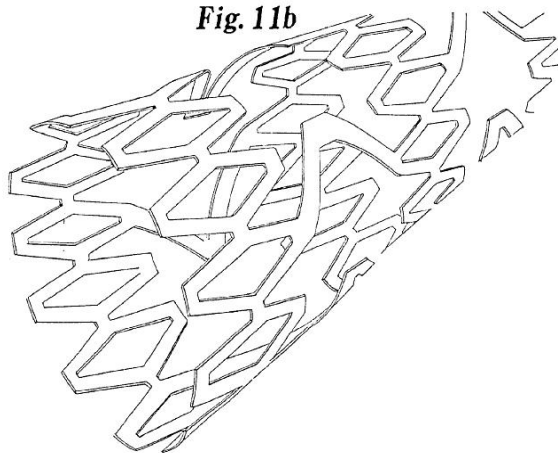

9

10 13. Burmeister WO discloses improving flexibility by omitting connecting
11 members. Omitted connecting members 100 are labeled in Figures 10a and 10b,
12 depicted below. (Burmeister WO 12:11-25).

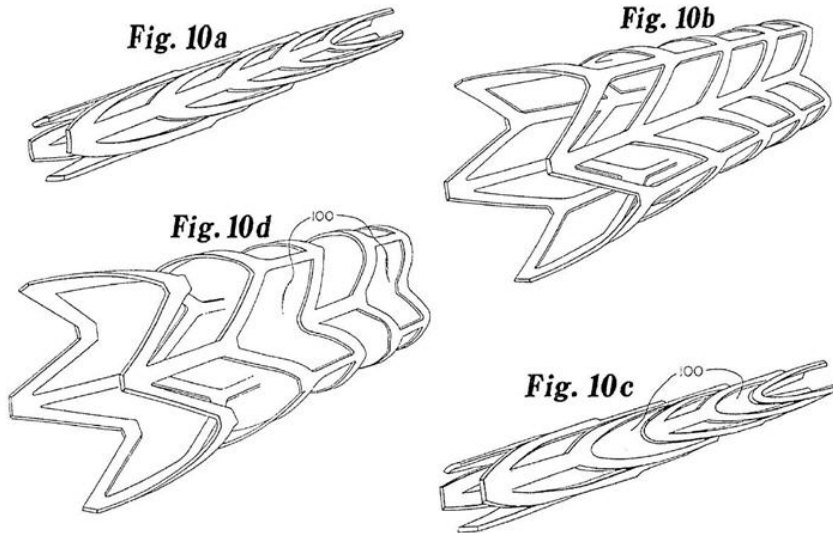

1

2 14. Burmeister WO discloses stents having open and closed configurations.
3 With an open configuration corresponding to a stent with omitted connecting
4 members, and a closed configuration corresponding to a stent with all connecting
5 members. Figures 10a and 10b, depicted above, represent stents in a closed
6 configuration, and figures 10c and 10d, depicted above, represent stents in an
7 open configuration. (Burmeister WO 12:11-25).

8 15. Burmeister WO discloses expandable stents having spaces between alternating
9 struts that form a spiral pattern. Figures 8a and 8b are illustrated below:

Fig. 8a

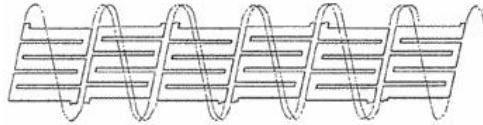
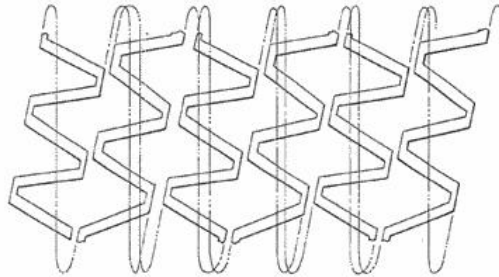

Fig. 8b



1
2
3

Jang '743

4 16. Jang '743 discloses an expandable stent having expansion struts 28,
5 connecting struts 38, and joining struts 30, (Jang '743 4:66-5:54), as shown in
6 Fig. 1A.

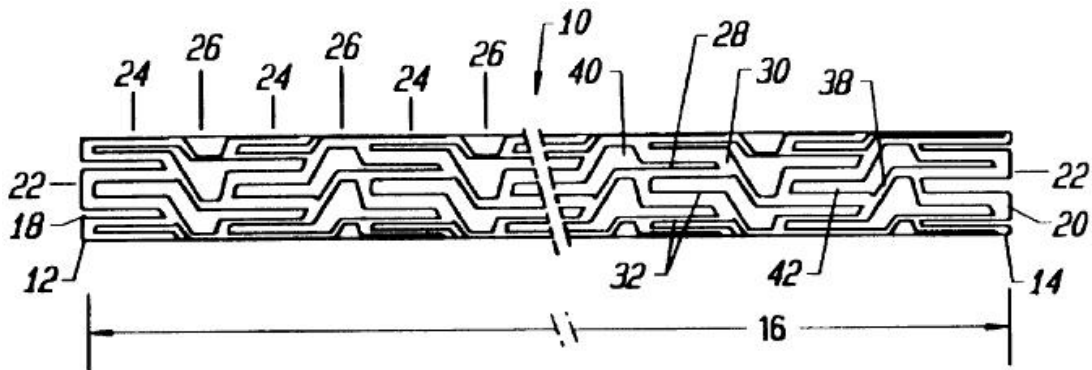

FIG. 1A

7
8
9
10
11

17. Jang '743 discloses an expandable stent that has substantially constant
unexpanded and expanded longitudinal lengths. (Jang '743 7:52-54).
18. Jang '743 discloses an expandable stent wherein the foreshortening of
struts 28 during expansion is countered by the longitudinal lengthening of

1 connecting struts 38, as depicted below in Figs. 3A and 3B (Jang '743 7:42-54):

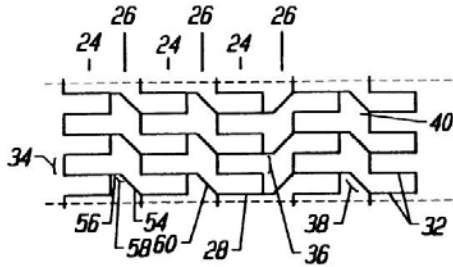

FIG. 3A

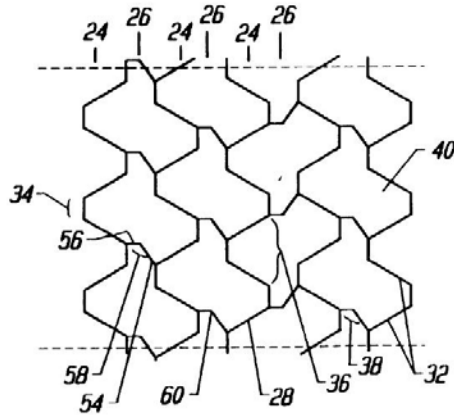

FIG. 3B

2
 3 19. Also, Jang '743 discloses several ways to achieve a tapered expanded
 4 stent, one of which involves removing progressively larger portions of the
 5 expansion struts 28 to remove corresponding ones of segments 72, 74, 76,
 6 78, 80, 82, and 84 shown in Figure 5 (Jang '743 9:9-10:38):

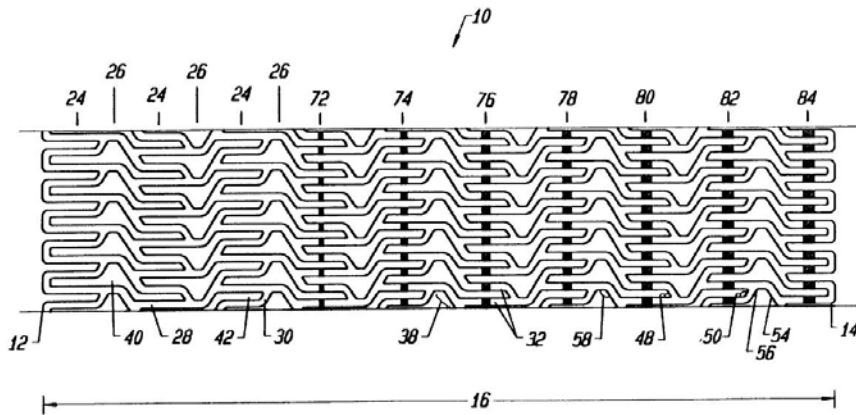

FIG. 5

7

8

Goicoechea '627

1

2 20. Goicoechea '627 discloses a bifurcated stent that has segments with
3 different diameters (12, 44) and segments that are tapered (14, 18). (Goicoechea
4 '627 8:50-63). See Fig. 20 depicted below:

FIG. 20

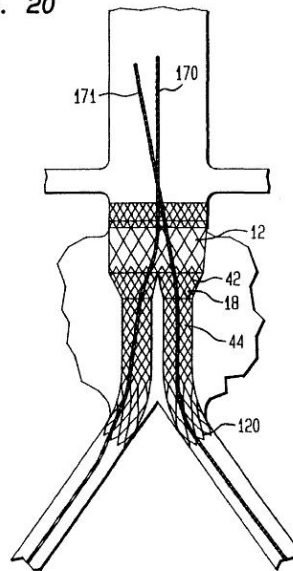

5

6 21. Goicoechea '627 discloses a stent made of Nitinol having a plurality of single
7 hoops 20 of unit width and intermediate hoops 25 of twice unit width, which are
8 connected by securing means made of Nitinol elements or polypropylene filaments.
9 (Goicoechea '627 9:1-61). See Fig. 2A reproduced below:

FIG. 2A

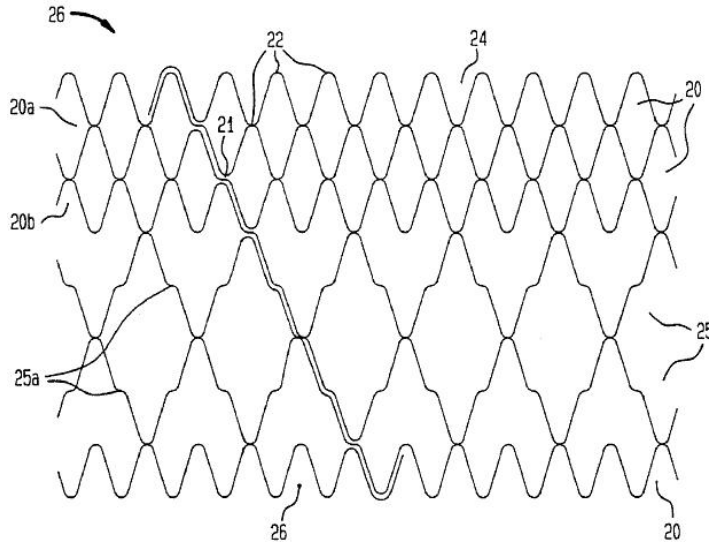

1

2 22. Goicoechea '627 discloses a stent with intermediate hoops 25 having a
3 plurality of offsets 25a that are created when Nitinol wire is wound around pins
4 instead of creating single hoops 20. (*Id.*)

5 23. Intermediate hoops 25 are formed by omitting single hoops 20, which leave
6 apices 22 unconnected where the stent transitions from intermediate hoops 25 to
7 single hoops 20. (*Id.*)

8 24. Intermediate hoops 25 are the size of four single hoops 20, and formed by
9 omitting two single hoops 20 connected at their apices 22. (*Id.*)

10

Fischell '825

11 25. Fischell '825 discloses dual diameter stents to accommodate a non-uniform
12 diameter vessel (Fischell '825 5:31-46), as illustrated in Fig. 5 reproduced below:

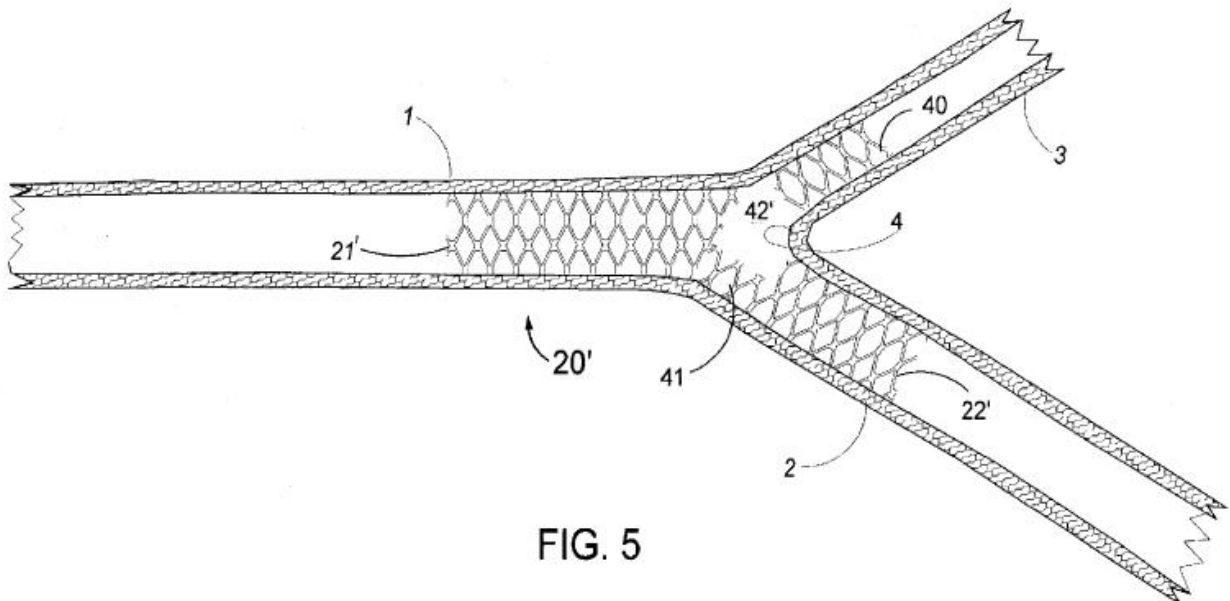

1

2 26. Fischell '825 teaches creating an opening to allow unobstructed blood flow by
3 not connecting alternating struts and apices. (Fischell '825 1:43-67; 4:31-41).

4

Analysis

5

6 Roubin's Motion 1 seeks to designate claims 8, 10-12, 16-19, and 21-54 of
7 Roubin '321, claims 1-25 of Roubin '236, and claims 1-12 of Roubin '548 as not
8 corresponding to the count. Roubin as the moving party bears the burden of
9 proof to establish entitlement to the relief requested. 37 C.F.R. § 41.121(b). A
10 claim corresponds to a count if the subject matter of the count, treated as prior art
11 to the claim, would have anticipated or rendered obvious the subject matter of the
12 claim. 37 C.F.R. § 41.207(b)(2).

12

13 It is evident that the count, if treated as prior art, would not have
14 anticipated any of the Roubin claims which the motion seeks to designate as not
15 corresponding to the count. Thus, the proper analysis is one of obviousness per
Graham v. John Deer Co., 383 U.S. 1 (1966). The pertinent factual inquiries are

Interference No. 105,794
Roubin v. Burmeister

1 (1) the scope and content of the prior art, (2) the differences between the claimed
2 invention and the prior art, (3) the level of ordinary skill in the art, and (4) any
3 objective evidence of nonobviousness. *Id.* at 17. One cannot show non-
4 obviousness by attacking references individually where the rejections are based
5 on combinations of references. *In re Keller*, 642 F.2d 413, 426 (CCPA 1981).

6 Also, a person of ordinary skill in the art has ordinary creativity and is not
7 an automaton. *KSR Int'l Co. v. Teleflex Inc.*, 550 U.S. 398, 421 (2007). If a
8 technique has been used to improve one device, and a person of ordinary skill in
9 the art would recognize that it would improve similar devices in the same way,
10 using the technique is obvious unless its actual application is beyond his or her
11 skill. *KSR Int'l Co.*, 550 U.S. at 417.

12 Roubin has to demonstrate by a preponderance of the evidence that each of
13 the claims it seeks to designate as not corresponding to the count would not have
14 been obvious to one with ordinary skill in the art, given the subject matter of the
15 count as prior art and any other applicable prior art. In that regard, Roubin
16 identifies many differences between the claims and the count.

17 For all of the reasons discussed below, Roubin has not satisfied its burden
18 of proof that the collective differences between each claim it seeks to designate as
19 not corresponding to the count and the subject matter of the count are such that
20 the claim would not have been obvious over the count.

21 At the outset, it is noted that the Board had given notice to Roubin that it
22 may not in its motion to designate claims as not corresponding to the count
23 restrict its analysis to only the prior art of record in either party's involved
24 application or patent but must address the level of ordinary skill in the art as well

1 as that prior art otherwise known to Roubin. (Paper 26). In its Motion 1, Roubin
2 discusses only the prior art of record and makes no representation that it is
3 unaware of any prior art which discloses the various features it alleges is missing
4 from the subject matter of the count. It cannot be assumed that the prior art of
5 record is the closest prior art for the features identified by Roubin as not present
6 within the count or that Roubin is not aware of other prior art disclosing such
7 features. For that reason alone, Roubin's Motion 1 motion is inadequate.

8 Additional deficiencies of Roubin's Motion 1 are discussed below.

9 A. Varying Diameter in the Expanded State

10 For claims 16-18, 23-25, and 51-53 of Patent 5,827,321, claims 1-25 of
11 Patent 6,475,236, and claims 3, 4, and 8-12 of Patent 6,106,548, Roubin correctly
12 points out that each claim requires a stent in the expanded state having two or
13 more segments along its length, with each segment assuming a different diameter
14 in the expanded state. The count has no such requirement and we refer to it as the
15 varying-diameter feature.

16 With regard to the varying diameter feature, Roubin specifically discusses
17 four prior art references identified in the prosecution history of Burmeister's
18 involved application and asserts that none makes up for the missing varying-
19 diameter feature: (1) Burmeister WO, (2) Jang '743, (3) Goicoechea '627, and
20 (4) Fischell '825.

21 With regard to Burmeister WO, we agree with Roubin that it does not
22 disclose a stent having multiple segments with different diameters. It neither
23 teaches nor suggests the varying-diameter feature. With regard to the other three
24 prior art references in combination with the subject matter of the count as prior

1 art, however, Roubin's arguments are misplaced.

2 Roubin asserts merely that implementing the varying-diameter feature
3 disclosed in each of Jang '743, Goicoechea '627, and Fischell '825 within the
4 subject matter of the count raises design considerations for one with ordinary skill
5 and makes it more difficult than it would be otherwise. But Roubin nowhere
6 asserts and the evidence does not support that implementing the varying-diameter
7 feature within the subject matter of the count would have been beyond the skill of
8 one with ordinary skill. Note that the subject matter of the count is treated as
9 prior art and Roubin acknowledges Jang '743, Goicoechea '627, and Fischell
10 '825 as prior art.

11 Each of Jang '743, Fischell '825, and Goicoechea '627 discloses a stent
12 including the varying-diameter feature. It would have been at least prima facie
13 obvious to one with ordinary skill in the art to include such a known feature into a
14 stent according to the count treated as prior art. Roubin can rebut the prima facie
15 case of obviousness by making a showing that the combination would have been
16 so technically complex that it could not have been accomplished by one with
17 ordinary skill in the art and that one with ordinary skill in the art would not have
18 expected to successfully complete the combination. However, Roubin makes no
19 such assertion, much less submit evidence sufficient to demonstrate the same.

20 That implementing the varying-diameter feature of Jang '743, Goicoechea
21 '627, or Fischell '825 in the subject matter of the count would involve design
22 considerations is certainly expected. That should be the beginning of Roubin's
23 analysis, not the end. A person of ordinary skill in the art is presumed to have
24 skills apart from what the prior art references explicitly say. *KSR Int'l Co.*, 550

Interference No. 105,794
Roubin v. Burmeister

1 U.S. at 418. One with ordinary skill in the art is a person of ordinary creativity
2 and is not an automaton. *Id.* at 421. Roubin has not asserted, much less
3 established, that the task of implementing the varying-diameter feature in
4 combination with the subject matter of the count would have been beyond the
5 level of ordinary skill in the art to accomplish and could not have been achieved
6 by one with ordinary skill in the art. Stopping short at stating that there will be
7 design considerations to contemplate seriously undermines Roubin’s analysis.

8 Moreover, Jang’743 discloses expansion and connecting struts that
9 correspond to the count’s annular elements and connecting members, (Jang ‘743
10 7:32-8:12). Jang ‘743 also discloses various methods to vary the diameter of
11 different segments of an expanded stent, which include changing the stiffness of
12 struts, using a tapered balloon to expand a non-tapered stent, employing
13 reinforced expansion struts; and removing portions of the expansion struts. (Jang
14 ‘743 9:10 to 10:38). One with ordinary skill in the art would have known to
15 include in its implementation effort at least the various methods disclosed in Jang
16 ‘743 which reflect the level of ordinary skill in the art.

17 B. Same Aperture Geometry/Different Aperture Size

18 For claims 21-32 of Patent 5,827,321, Roubin correctly points out that each
19 claim recites a stent with a first and a second segment wherein the apertures of the
20 first and second segments have different sizes but “substantially the same
21 geometric configuration” when the first and second segments are in the expanded
22 state. The count has no such requirement and we refer to it as the substantially-
23 the-same-geometry feature.

24 Based on that feature, Roubin seeks to designate claims 21-32 of Roubin

1 '321 as not corresponding to the count. In its argument, Roubin specifically
2 discusses Goicoechea '627, and asserts that it does not disclose apertures that
3 have different sizes but substantially the same geometric configuration in the
4 expanded state. We disagree.

5 Goicoechea '627 discloses apertures of different sizes but substantially the
6 same geometry as depicted in Fig. 2A shown above. Hoops 20 and 25 have
7 substantially the same geometric shape while hoop 20 has a unit width of one and
8 hoop 25 has a unit width of two. (Goicoechea '627 9:20-61). Hoops 20 and 25
9 are connected by securing means of Nitinol loops, creating annular elements
10 connected by connecting members. (*Id.*).

11 While it is true that large hoops 25 have perimeters which include a small
12 slightly undulating portion on each side due to the particular manner of
13 construction and the small hoops 20 do not, it cannot be reasonably disputed that
14 the overall contours of the small and large hoops are “substantially the same.”
15 The substantially-the-same geometry feature requires not identity of configuration
16 but only substantial sameness. Roubin gives no satisfactory explanation on why
17 the shapes of hoops 20 and 25 are not “substantially the same” as is claimed.

18 Even if the shapes of hoops 20 and 25 are considered not to be substantially
19 the same, it is not explained why one with ordinary skill in the art would not have
20 recognized from the disclosure of Goicoechea '627 that the contours of hoops 20
21 and 25 can be made substantially the same. In particular, Roubin cites no portion
22 of Goicoechea '627 which indicates that larger hoops 25 must be made with the
23 small slightly undulating portion on each side.

24

1 Roubin further argues that the apertures shown in Goicoechea ‘627 are not
2 of the same type as the ones recited in the count because in Goicoechea there are
3 no connecting members connecting adjacent annular elements. The argument is
4 without merit. The annular elements in Goicoechea ‘627 are the hoops 20 and 25,
5 and adjacent members of the hoops are connected in a number of different ways
6 such as Nitinol loops, rings, or staples. (Goicoechea ‘627 9:53-61). Roubin’s
7 argument is also misplaced because one cannot show non-obviousness by
8 attacking references individually where the issue involves a combination of
9 references. *In re Keller*, 642 F.2d 413, 426(CCPA 1981). Here, the count itself is
10 treated as prior art and Roubin does not adequately explain why the hoops of
11 Goicoechea cannot be connected as recited in the count.

12 C. Annular Element in an Open Configuration

13 For claims 8, 32, and 38-58 of Roubin ‘321, Roubin correctly points out
14 each claim requires a stent having at least one annular element in an open
15 configuration, *i.e.*, that the plurality of alternating struts and apices which define
16 an annular element are not connected in at least one location. (Motion 11:4-8).
17 The count has no such requirement and we refer to it as the open-element feature.

18 Roubin argues that based on the open-element feature alone, the claims
19 would not have been obvious to one having ordinary skill in the art over the
20 count. (*Id.* 13:13-19). Roubin discusses three references identified in the
21 prosecution history of Burmeister’s involved application and asserts that none
22 makes up for the identified difference between the claims and the count treated as
23 prior art: (1) Burmeister WO, (2) Goicoechea ‘627, and (3) Fischell ‘825.
24 Roubin asserts that each of the references, individually, does not teach the open-

1 element feature as required by the claims. The argument is misplaced

2 Roubin cannot show non-obviousness by attacking references individually
3 where the issue is based on a combination of prior art. *See In re Keller*, 642 F.2d
4 at 426. It cannot be ignored that the count is also treated as prior art. Also, a
5 person of ordinary skill is presumed to have skills apart from what the references
6 explicitly say. *KSR Int'l Co.*, 550 U.S. at 418. One with ordinary skill is also a
7 person of ordinary creativity and is not an automaton. *Id.* at 421.

8 Roubin acknowledges that Burmeister WO discloses omitting connecting
9 members to render a stent flexible for articulation. (Motion 11:29-12:1). Roubin
10 also acknowledges that Fischell '825 shows a stent with a plurality of integrally
11 connected struts which define annular elements with an open portion 42' between
12 portions of the stent 21', 22'. (*Id.* 12:29-13:6). Roubin does not adequately
13 explain why one with ordinary skill would not have known, in light of Burmeister
14 WO or Fischell '825, to omit in the subject matter of the count a connecting
15 member or a portion of a stent thus satisfying the open-element feature.

16 Furthermore, Goicoechea '627 discloses an expandable stent having
17 intermediate hoops created by omitting an annular element, *e.g.*, a single hoop,
18 leaving unconnected apices in an open configuration. (Goicoechea '627 9:20-33).
19 Roubin has not adequately explained why one with ordinary skill would not have
20 known, in light of Goicoechea '627, to omit in the subject matter of the count all
21 or a portion of an annular element thus leaving at least one annular element
22 unconnected at one location thus satisfying the open-element feature.

23

24

1 D. Gaps by Omitting Struts

2 For claims 35-37 of Patent 5,827,321, Roubin correctly points out that each
3 of these claims recites a stent having a plurality of gaps formed by omitting at
4 least one of the struts. The count has no such requirement and we refer to it as the
5 gap feature.

6 Roubin specifically discusses three prior art references: (1) Burmeister
7 WO, (2) Fischell '825, and (3) Goicoechea '627. Roubin alleges that none of the
8 three references teaches including the gap feature in subject matter of the count.
9 The argument is misplaced.

10 Roubin cannot show non-obviousness by attacking references individually
11 where the issue is based on a combination of prior art. *In re Keller*, 642 F.2d at
12 426. Here, it cannot be ignored that the count is also treated as prior art. Also, a
13 person of ordinary skill in the art is presumed to have skills apart from what the
14 prior art references explicitly say. *KSR Int'l Co.*, 550 U.S. at 418. One with
15 ordinary skill in the art is also a person of ordinary creativity and is not an
16 automaton. *Id.* at 421.

17 While Burmeister WO does not suggest removing a strut, Roubin
18 acknowledges that Burmeister WO discloses omitting connecting members to
19 render a stent flexible. (Motion 11:29-12:1). Burmeister WO discloses omitting
20 connecting members to create a gap. (Burmeister WO 12:11-16). Fischell '825's
21 Figure 5 discloses a gap in the expandable stent by omitting struts. (Fischell '825
22 4:31-41). Goicoechea '627 discloses offsets created by omitting a hoop to form a
23 gap. (Goicoechea '627 9:20-33). Thus, each of Burmeister WO, Fischell '825,
24 and Goicoechea '627 discloses a stent including the gap feature.

1 Roubin has not adequately explained why in light of Burmeister WO,
2 Fischell '825, and Goicoechea '627, one with ordinary skill in the art would not
3 have known to form the gap feature within the subject matter of the count.

4 E. Consistent Length between Expanded and Compressed States

5 For claim 7 of Patent 6,475,236, Roubin correctly points out that the claim
6 recites a stent wherein the length is consistently maintained throughout expansion
7 of the stent from the compressed state. The count has no such requirement and
8 we refer to it as the consistent-length feature.

9 Roubin argues that one of ordinary skill in the art would not have expected
10 that a stent according to the count would necessarily consistently maintain the
11 length of the stent from the compressed to the expanded state. (Motion 15:11-
12 15). The argument is misplaced. The issue is not whether a stent according to the
13 count would necessarily include the consistent-length feature, but whether the
14 consistent-length feature would have been obvious to one with ordinary skill
15 when the count is treated as prior art.

16 Roubin further argues that even if Jang '743 did teach a stent with reduced
17 foreshortening, the design would not have suggested the consistent-length feature.
18 (*Id.* 15:27-32). The argument lacks underlying analysis and is unpersuasive.

19 Jang '743 teaches an expandable stent that has a substantially constant
20 unexpanded and expanded longitudinal length to help alleviate the foreshortening
21 of a stent from the compressed to the expanded state. (Jang '743 7:42-54; 9:10-
22 65). It would have been at least *prima facie* obvious to one with ordinary skill in
23 the art that if the stent in its compressed and expanded states has substantially the
24 same length, then it likely has substantially the same length during the transition

1 from the compressed to the expanded state. Moreover, Jang ‘743 does not
2 disclose a substantially different stent length during the transition. That
3 implementing the consistent-length feature of Jang ‘743 in the subject matter of
4 the count would involve design considerations is expected. That should be the
5 beginning of Roubin’s analysis and not the end. A person of ordinary skill in the
6 art is presumed to have skills apart from what the prior art references explicitly
7 say. *KSR Int’l Co.* 550 U.S. at 418. One with ordinary skill in the art is also a
8 person of ordinary creativity and is not an automaton. *Id.* at 421. Roubin has not
9 asserted, much less established, that the task of implementing the consistent-
10 length feature in combination with the count would have been beyond the level of
11 ordinary skill in the art to accomplish and could not have been achieved by one
12 with ordinary skill in the art.

13 F. Spiral Pattern of Omitted Connecting Members or Struts

14 Claim 34 refers to omitting connecting members of an expandable stent
15 with a plurality of segments, with the omitted connecting members forming a
16 spiral pattern on the stent. Claim 37 similarly refers to omitting struts of the stent,
17 with the omitted struts forming a spiral pattern on the stent. We refer to the
18 limitation in claim 34 and the limitation in claim 37 as the spiral-pattern-omission
19 feature.

20 With regard to the spiral pattern feature, Roubin specifically discusses only
21 Burmeister WO and Goicoechea ‘627. We agree with Roubin that the subject
22 matter of the count in combination with either Burmeister WO or Goicoechea
23 ‘627 would not have reasonably suggested the spiral-pattern-omission feature.

24 However, Roubin still has not met its burden of proof by a preponderance

1 of the evidence. The hypothetical person of ordinary skill in the art is not aware
2 of not just Burmeister WO and Goicoechea '627. We recognize that Roubin
3 cannot be presumed to have been aware of every item of prior art as would the
4 hypothetical person of ordinary skill in the art. But it must account for prior art
5 which it is aware. With respect to the spiral-pattern-omission feature, if Roubin is
6 aware of no closer prior art than Burmeister WO and Goicoechea '627, its simply
7 stating so may suffice. There is no such representation in Roubin's Motion 1.

8 Roubin apparently responds only to arguments made in Burmeister's
9 suggestion for interference, rather than establishes independently, as it should,
10 that the claims are patentably distinct from the count. That seriously undermines
11 the motion for which Roubin bears the burden of proof.

12 As is already noted above, the Board had given explicit notice to Roubin
13 that it may not restrict its analysis to only the prior art of record in either party's
14 involved application or patent but must address the level of ordinary skill in the
15 art as well as that prior art otherwise known to Roubin. (Paper 26). Roubin
16 makes no representation that it is unaware of any prior art which discloses the
17 spiral-pattern-omission feature.

18 G. Biocompatible Graft Covering

19 For claim 19 of Roubin '321, Roubin correctly notes that it comprises a
20 stent according to the count in combination with a biocompatible graft covering.

21

22 The only disclosure of the biocompatible graft covering in Roubin's
23 specification is reproduced in its entirety below (Roubin '321 5:15-18):

24 The stent may also be coated with coverings of PTFE, dacron, or

Interference No. 105,794
Roubin v. Burmeister

1 other biocompatible materials to form a combined stent-graft
2 prosthesis.

3
4 In arguing that implementing the biocompatible graft covering in
5 combination with the count would not have been obvious to one of ordinary skill
6 in the art, Roubin specifically discusses only one reference - Goicoechea '627.
7 Roubin asserts that implementing the covering feature raises “additional,
8 independent design considerations . . . because of the function of the connecting
9 members.” (Motion 18:21-24).

10 Goicoechea '627 discloses a biocompatible graft covering in combination
11 with an expandable stent. (Goicoechea '627 10:30-39). The count discloses an
12 expandable stent having connecting members preset with an elasticity to elongate
13 longitudinally to compensate for smaller longitudinal dimensions of expanded
14 annular elements. Notwithstanding the connecting elements with a preset
15 elasticity in the expandable stent of the count, there is at least a prima facie case
16 of obviousness for one with ordinary skill in the art to implement the
17 biocompatible graft covering in the expandable stent of the count. After all, the
18 stent is for use within the body and Goicoechea clearly discloses the desirability
19 of using a biocompatible graft covering on such a stent.

20 That implementing the biocompatible-graft feature in combination with the
21 subject matter of the count would involve design considerations is expected. But
22 that should be the beginning of Roubin's analysis, not the end. A person of
23 ordinary skill in the art is presumed to have skills apart from what the prior art
24 references explicitly say. *KSR Int'l Co.* 550 U.S. at 418. One with ordinary skill
25 in the art is also a person of ordinary creativity, and not an automaton. *Id.* at 421.

1 Roubin has not asserted, much less established, that implementing the
2 biocompatible-graft feature in the subject matter of the count would have been
3 beyond the level of ordinary skill in the art or unachievable by one with ordinary
4 skill in the art. Roubin also has not asserted or demonstrated that one with
5 ordinary skill would not have expected a successful implementation.

6 Furthermore, claim 19 depends from claim 1 which serves as an alternative
7 in the count. Roubin points to nothing in its own disclosure which constitutes a
8 special way of implementing the biocompatible graft covering on a stent
9 including elongating connecting members to compensate for foreshortening.
10 That is a further indication that the implementation is within the level of ordinary
11 skill in the art.

12 H. Same Length in the Expanded State and Compressed State

13 For claims 1-8, 12, 17, 20, 22, and 25 of Roubin '236, Roubin correctly
14 notes that these claims recite a stent having segments with varying diameter in
15 the expanded state while the length of the stent remains the same in both the
16 expanded and compressed states. (Motion 19:13-23). Roubin correctly notes
17 that this feature requires a stent to have no foreshortening between the
18 compressed and expanded states. (*Id.*). The count has no such requirement and
19 we refer to it as the same-length feature.

20 Roubin argues that one of ordinary skill in the art would not have thought
21 to implement a stent wherein the length of the stent is the same in the expanded
22 and the compressed state, and further argues that the same-length feature would
23 not have been obvious in view of the count. (Motion 19:13-25).

24 The argument is unpersuasive.

1 Jang '743 teaches an expandable stent that has a substantially constant
2 unexpanded and expanded longitudinal length to help alleviate the foreshortening
3 of a stent from the compressed to the expanded state. (Jang '743 7:42-54; 9:10-
4 65). It would have been at least prima facie obvious to one with ordinary skill in
5 the art to include that desirable feature within the subject matter of the count.
6 Roubin can rebut the prima facie case of obviousness by making a showing that
7 the combination would have been so technically complex that it would have been
8 beyond the level of ordinary skill to implement and that one with ordinary skill in
9 the art would not have expected to successfully complete the implementation.
10 However, Roubin has made no such showing.

11 That implementing the same-length feature of Jang '743 in the subject
12 matter of the count would have involved design considerations is expected. That
13 should be the beginning of Roubin's analysis, not the end. A person of ordinary
14 skill in the art is presumed to have skills apart from what the prior art references
15 explicitly say. *KSR Int'l Co.* 550 U.S. at 418. One with ordinary skill in the art
16 is also a person of ordinary creativity, and not an automaton. *Id.* at 421. Roubin
17 has not asserted, much less established, that the task of implementing the same-
18 length feature in combination with the subject matter of the count would not have
19 been achievable by one with ordinary skill in the art.

20 I. First Segment having a Plurality of
21 Combined Adjacent Cells that Impart Greater
22 Flexibility to the First Segment than the Second Segment

23 For claims 1-7 of Patent 6,106,548, Roubin correctly points out that they
24 recite a stent having a first segment with a plurality of combined adjacent cells

1 that impart greater flexibility to the first segment than to the second segment.
2 (Motion 19:28-20:1). The count has no such requirement and we refer to it as the
3 flexible-segment feature.

4 Roubin discusses Figures 11a and 11b of Burmeister WO (Motion 20:3-
5 13) but not that part of Burmeister WO teaching that connecting members are
6 removed from portions of the stent to form segments of different flexibility.
7 (Burmeister WO 12:11-16; Figures 10a-10d). Thus, Roubin's argument about
8 Burmeister WO is unpersuasive. Roubin also cannot show non-obviousness by
9 attacking references individually where the matter is based on a combination of
10 prior art. *In re Keller*, 642 F.2d at 426. Here, the count is regarded as prior art.
11 Also, Goicoechea '627 discloses an expandable stent having a segment formed of
12 small hoops of unit width and a segment of intermediate hoops of twice unit
13 width. (Goicoechea '627 9:20-33). The latter has more flexibility and each
14 intermediate hoop has four adjacent small hoop cells. (*Id.*). Roubin's not
15 discussing Goicoechea's disclosure in connection with the flexible-segment
16 feature also renders its argument unpersuasive.

17 Conclusion

18 For all of the foregoing reasons, and considering collectively all of the
19 differences Roubin has identified for each claim with respect to the subject matter
20 of the count, Roubin has not satisfied its burden of proof in showing that it is
21 entitled to the relief requested, *i.e.*, to have claims 8, 10-12, 16-19, and 21-54 of
22 Roubin '321, claims 1-25 of Roubin '236, and claims 1-12 of Roubin '548
23 designated as not corresponding to the count.

24 Roubin's Motion 1 is *denied*.

Interference No. 105,794
Roubin v. Burmeister

1 By Electronic Transmission:

2

3 Counsel for Roubin:

4

5 John T. Callahan

6 Keiko K. Takagi

7 SUGHRUE MION, PLLC

8 jcallahan@sughrue.com

9 ktakagi@sughrue.com

10

11

12 Counsel for Burmeister:

13

14 William F. Lawrence

15 Stephen J. Lieb

16 Frommer Lawrence & Haug, LLP

17 wlawrence@flhlaw.com

18 slieb@flhlaw.com